

CEV-30 • CEV-40 Post-mix Countertop Electric Dispensers



Servend.



CEV-30 • CEV-40

Servend's post-mix countertop electric beverage dispensers offer maximum beverage cooling and customer-satisfying quality. The CEV series is designed for quick, easy installation with front and top access to all major components.

- Enhanced design aesthetics with modular assembly.
- Angled wrap-around illuminated merchandiser.
- Easy to service with quick access to air filter for cleaning and side by side placement of split carbonation and refrigeration decks. Easy slide on/off drain pan.
- Flex manifold adds carb/non-carb flexibility.
- New technology includes plug and play consolidated circuit board with protection for pump and compressor.
- 360° graphics enhance aesthetics and increase promotion of fountain beverages.



ISO 9001:2000
Quality System Certified

Leader in Ice & Beverage Dispensers

Countertop Ice/Bev • Drop-in • Countertop Electric • Undercounter

Manitowoc
Foodservice Group

CEV-30 • CEV-40 Post-mix Countertop Electric Dispensers

Specifications

	CEV-30 <i>with internal carbonation system</i>	CEV-40 <i>with internal carbonation system</i>
Standard Features	Key switch, 3/8" (0.95 cm) barbed fittings, Flomatic 424 beverage valves, 4" (10.16 cm) adjustable legs, drain kits and integral cold carbonator	
Dimensions	20.50" W x 28.16" D x 29.88" H 52.07 W x 71.54 D x 75.90 H (cm)	25.75" W x 28.16" D x 29.88" H 65.41 W x 71.54 D x 75.90 H (cm)
Cup Clearance	11.77" (29.88 cm) height from grid to valve nozzle	
Exterior Body	Replaceable stainless steel panels	
Exterior Bonnet	Replaceable injection molded ABS plastic	
Water Tank	Double wall rotocast, foam-filled polyethylene	
Manifold	6 valve: (1) fixed as carb only (5) carb or noncarb manifold	8 valve: (3) fixed as carb only (5) carb or noncarb manifold
Valves	6 Flomatic post-mix valves	8 Flomatic post-mix valves
Electrical Requirements	120V/60Hz/8.2FLA • 208-230V/60Hz/1 (export). Consult factory for options	
Ice Bank Control	Consolidated circuit board with pump and compressor protection capabilities	
Compressor	Tecumseh 1/3 HP	
Refrigerant	R-134a	
Refrigerant Deck	Independent lift out	
Carbonation Deck	Independent lift out	
Ice Bank Size (Nominal)	30-32 lbs. / 13.61-14.51 kgs.	
Options	Flomatic valves are available in sanitary lever, push button, & portion control. Other valves available. Lighted merchandiser, external carbonator configuration available	
Shipping Weights	173 lbs. / 78.5 kgs.	190 lbs. / 86.2 kgs.

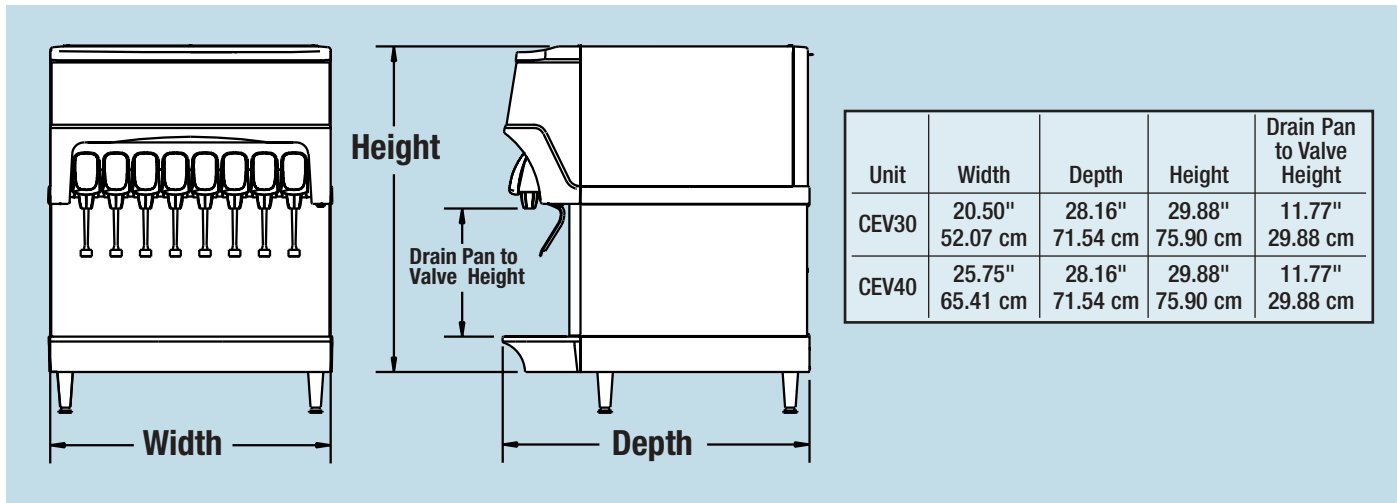

2146 ©2004 Servend SDC. Continuing product improvement may necessitate change of specifications without notice.



MANITOWOC BEVERAGE
EQUIPMENT, INC.
2100 Future Drive
Sellersburg, IN 47172, USA
Ph: 812-246-7000 • Fax: 812-246-7024
Visit us online at www.manitowocbeverage.com

